

**MODELS:**

**100(55)  
65AT  
66  
85  
85S  
88**



**AIR  
POWERED  
AND  
MAGAZINE FED**

# HARTCO CLINCHING TOOLS

## INSTRUCTION AND PARTS MANUAL

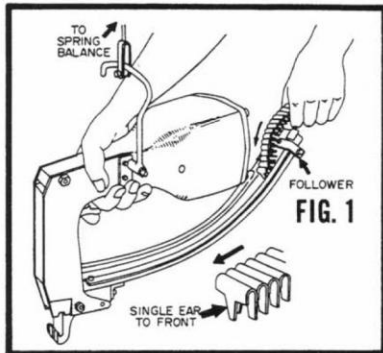

**Operation**

Clips may be loaded into the magazine by pulling the follower to the rear of the magazine where it latches (Fig. 1). Insert clips **with single ear to the front** and release follower latch. The tool is now ready for clinching. Simply locate the wires in the side plate notch and squeeze the trigger.

**IMPORTANT:** Place wires in notch of side plates by pushing tool **down** onto wires as shown in Fig. 2.

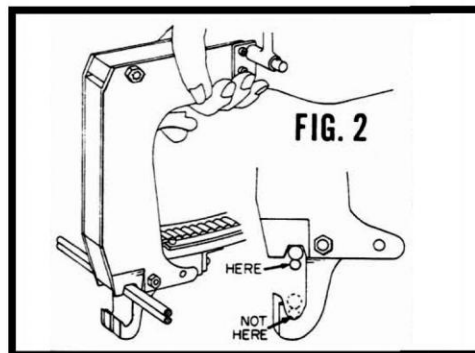

**Installation & Air Supply**

As this tool weighs approximately 7 pounds, it can be balanced on a suspension cable using a 5-10 pound spring balancer (Fig. 1). Recommended air pressure for the Hartco Clinching Tool is a minimum of 80 PSI and maximum of 110 PSI.

A 3/8" I.D. flexible hose should be attached to the tool by means of a quick-disconnect fitting. When tightening the quick-disconnect fitting, place a wrench on the hex end of the main valve assembly and tighten the fitting against this wrench. **DO NOT APPLY TORQUE TO THE MAIN VALVE ASSEMBLY AS THIS CAN BREAK THIS VALVE.**

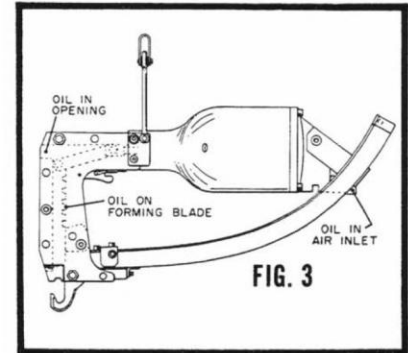

**Maintenance**

The Hartco Clinching Tool is of simple design with a minimum of parts and will give long years of service when used correctly. Oil daily (Fig. 3) with 30 weight oil and maintain the tool as follows:

- 1) A drop or two of oil in the air inlet of the tool is recommended on a daily basis. Oil blade at same time.
- 2) The front of the driver blade should be well greased whenever the tool is disassembled.
- 3) Tighten bolts as necessary.
- 4) Use wire to clean tape from blade slot.



... Innovating Legendary Products

For customer service and product support, contact:

**PackagingAndFastening.com**

USA Phone: 1-714-809-0194  
www.packagingandfastening.com

# PARTS IDENTIFICATION

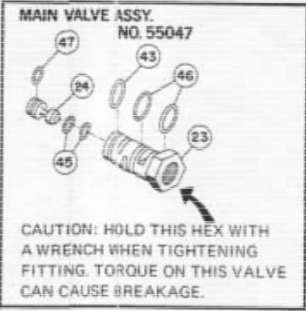
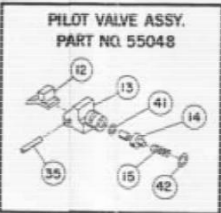
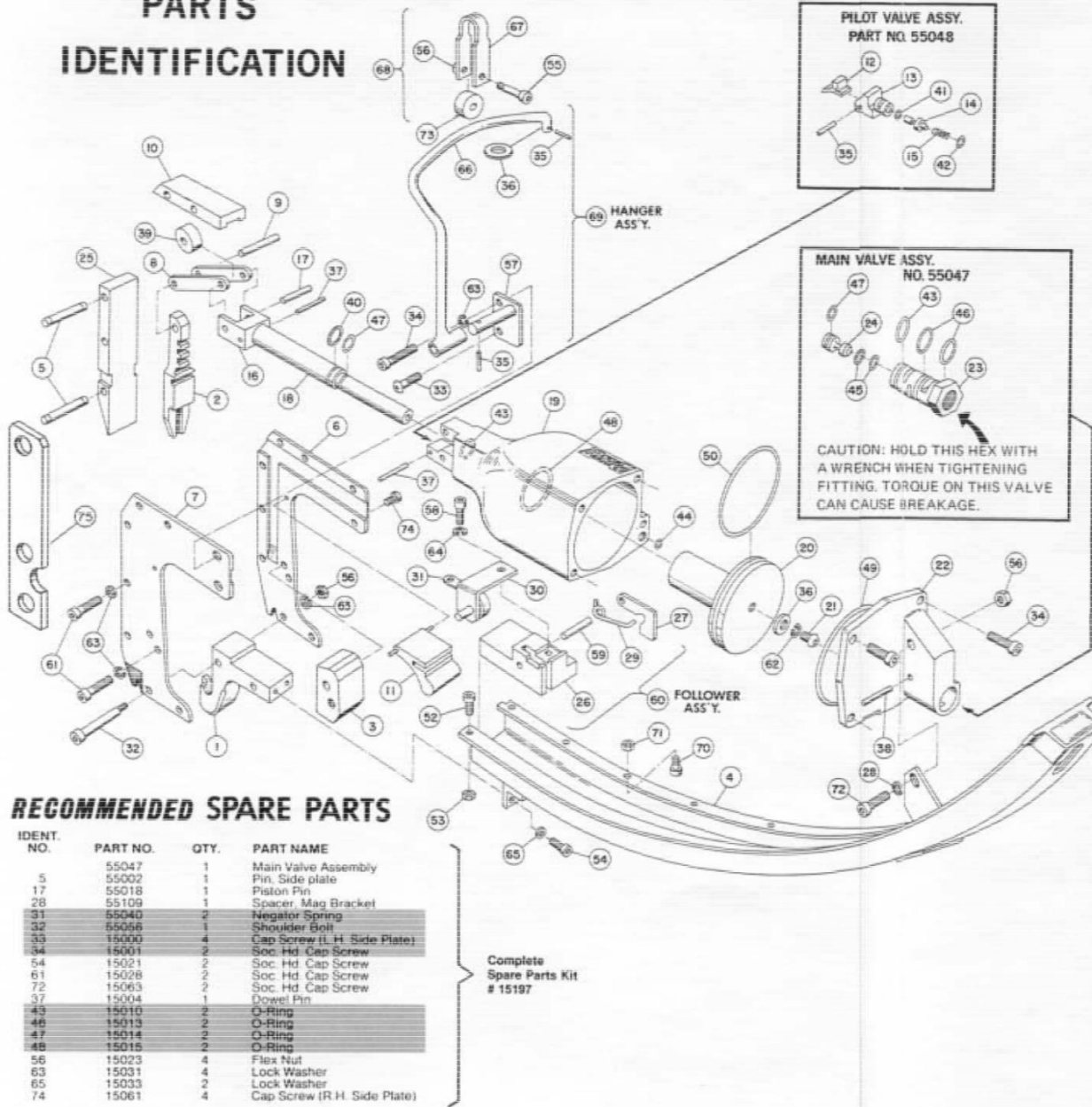

## RECOMMENDED SPARE PARTS

IDENT. NO.	PART NO.	QTY.	PART NAME
5	55047	1	Main Valve Assembly
5	55002	1	Pin, Side plate
17	55018	1	Piston Pin
28	55109	1	Spacer, Mag Bracket
31	55040	2	Negator Spring
32	55056	1	Shoulder Bolt
33	15000	4	Cap Screw (L.H. Side Plate)
34	15001	2	Soc. Hd. Cap Screw
54	15021	2	Soc. Hd. Cap Screw
61	15028	2	Soc. Hd. Cap Screw
72	15063	2	Soc. Hd. Cap Screw
37	15004	1	Dowel Pin
43	15010	2	O-Ring
46	15013	2	O-Ring
47	15014	2	O-Ring
48	15015	2	O-Ring
56	15023	4	Flex Nut
63	15031	4	Lock Washer
65	15033	2	Lock Washer
74	15061	4	Cap Screw (R.H. Side Plate)

Complete Spare Parts Kit # 15197

# PARTS LIST

IDENT. NO.	PART NAME	QTY.	PART NUMBER						
			MODEL 100(55)®	MODEL 65AT	MODEL 66	MODEL 65	MODEL 65S	MODEL 66	
1	Anvil	1	55001	55098-01	55171	55114	55175	55188	
2	Blade	1	55006	55099-01	55172	55106	55176	55189	
3	Blade Guide	1	55005	55102	55005	55177	55177	55193	
4	Magazine Assembly	1	55027	55101	55027	55108	55178	55197	
5	Pin, Side Plate	5	55002	55002	55002	55002	55002	55002	
6	Side Plate R.H.	1	55003	55003	55003	55003	55173	55191	
7	Side Plate L.H.	1	55004	55004	55004	55004	55174	55192	
8	Link	2	55008	(The following parts are the same for all models)					
9	Pin - Former	1	55009						
10	Top Plate	1	55011						
11	Trigger	1	55012						
12	Valve Lever	1	55013						
13	Pilot Valve Body	1	55014						
14	Pilot Valve Stem	1	55015						
15	Spring	1	55016						
16	Yoke	1	55017						
17	Piston Pin	1	55018						
18	Piston Rod With O Rings	1	55019						
19	Housing With O Rings	1	55020						
20	Piston	1	55021						
21	Piston Cap Screw	1	55022						
22	Cap With O Ring	1	55023						
23	Valve Body With O Rings	1	55024						
24	Valve Piston With O Ring	1	55025						
25	Front Plate	1	55027						
26	Follower	1	55031						
27	Latch, Follower	1	55032						
28	Spacer, Magazine Bracket	1	55109						
29	Spring, Follower Latch	1	55038						
30	Follower Bracket Assembly	1	55039						
31	Negator Spring	1	55040						
32	Shoulder Bolt	2	55056						
33	Button Hd. Cap Sc. 1/2-20-5/8	2	15000						
34	Soc. Hd. Cap Sc. 1/4-20-3/4	5	15001						
35	Roll Pin 3/32 x 1/2	3	15002						
36	Washer 3/8 I.D.	2	15036						
37	Dowel Pin 1/8 x 7/8	2	15004						
38	Roll Pin 5/32 x 1	1	15005						
39	Roller	1	55103						
40	O Ring 3/8 x 9/16	1	15054						
41	O Ring 1/8 x 1/4	1	15008						
42	O Ring 5/16 x 7/16	1	15009						
43	O Ring 9/16 x 3/4	2	15010						
44	O Ring 1/4 x 3/8	1	15011						
45	O Ring 3/8 x 9/16	2	15012						
46	O Ring 5/8 x 3/4	2	15013						
47	O Ring 3/8 x 1/2	2	15014						
48	O Ring 1 x 1 1/2	1	15015						
49	O Ring 2-7/8 x 3	1	15016						
50	O Ring 2-3/4 x 3-1/8	1	15017						
51	Soc. Hd. Cap Sc. 9-32 x 1/4	1	15019						
52	Flex-Nut - Thin 9-32	1	15020						
54	Soc. Hd. Cap Sc. 10-32 x 1/2	2	15021						
55	Soc. Hd. Cap Sc. 1/4-20 x 1	2	15022						
56	Flex-Nut - Std. 1/4-20	4	15023						
57	Hanger Support	1	55053						
58	Soc. Hd. Cap Sc. 8-32 x 5/8	1	15025						
59	Roll Pin 1/8 x 3/4	1	15026						
60	Follower Assembly	1	55051						
61	Soc. Hd. Cap Sc. 1/4-20-5/8	4	15028						
62	Lock Washer 5/16 I.D.	1	15029						
63	Lock Washer 1/4 I.D.	7	15031						
64	Lock Washer	1	15032						
65	Lock Washer	2	15033						
66	Suspension Hanger	1	55096						
67	Hanger Yoke	1	55095						
68	Hanger Yoke Assembly	1	55094						
69	Suspension Hanger Assembly	1	55097						
70	Soc. Hd. Cap Sc. 5-40-3/8	4	15052						
71	Flex Lock-Nut 5-40	4	15053						
72	Soc. Hd. Cap Sc. 1/4-20 x 1 1/2	1	15063						
73	Roller Bearing	1	15037						
74	Button Hd. Cap Screw 1/2x20x1/2	2	15061						
75	Side Plate Strap	2							

NOTES:  
 ① Model 100 has multiple configurations based on the application. Please make note of items 1 through 7, as your tool might differ from what is shown in the table.  
 ② Use 55218 to clip border below coils.

## WARNING

**Keep Fingers and Hands Away From Jaws  
 This Tool Squeezes With 2,000 Pounds of Force**  
 Instruct operators to use the Hartco Clinching Tool without placing hands or fingers near blade or anvil (jaws). Put wires only between blade and anvil. Never put fingers between blade and anvil. When clearing jams or repairing tool, be sure air is disconnected.

55194  
55195

55199

15066

55196

# APPLICABLE WIRE GAUGE COMBINATIONS

## FURNITURE CLIP AND WIRE GAUGE COMBINATIONS

For these wire sizes . . . . . Use this tool and clip

12 ga. to 8, 9, 10, 11 & 12 ga.  
 11 ga. to 9, 10, 11 & 12 ga. Model 65AT-CL-23  
 10 ga. to 10, 11 & 12 ga. or  
 Paper covered to 8, 9, 10, Model 66-CL-3  
 11 & 12 ga.

10 ga. to 8, 9 & 10 ga.  
 9 ga. to 8, 9, 10 & 11 ga. Model 65AT-CL-24  
 8 ga. to 8, 9, 10 & 11 ga. or  
 7 ga. to 8, 9, 10 & 11 ga. Model 66-CL-4  
 6 ga. to 10 & 11 ga.

There are two models of tools to choose from for the furniture applications, the model 65AT or Model 66.

The Model 65AT performs best when clipping over two wires that are straight and parallel at the section where the wire is applied.

The Model 66 performs best in the clipping of coil springs to border wires or the clipping of non parallel sinuous wire.

## BOX SPRING CLIP AND WIRE COMBINATIONS

For these wire sizes . . . . . Use this tool and clip

6 ga. border to 8, 9, 10, 11 ga. coil  
 4 ga. border to 8, 9, 10, 11 ga. coil Model 85-CL-34  
 3 ga. border to 9, 10, 11 ga. coil  
 3 ga. border to 8, 9, 10, 11 ga. coils Model 85S-CL-36  
 2 ga. border to 9, 10, 11 ga. coils  
 00 ga. to 8, 9, 10, 11 coils Model 88-CL-38

## AUTOMOTIVE SPRING CLIP AND WIRE COMBINATIONS

For these wire sizes . . . . . Use this tool and clip

8 ga. flat to 11, 12 ga. rd. Model 100(55)-CL-3  
 11 ga. rd. to 10, 11 & 12 ga. rd.  
 8 ga. flat to 8, 9, 10 ga. rd.  
 8 ga. rd. to 8, 9, 10 ga. rd. Model 100(55)-CL-4  
 9 ga. rd. to 8, 9, 10 ga. rd.

NOTE: Items 1 through 7 must be specified when ordering a Model 100 clipping tool.

**Clipping is our only business — If you have a special application, ask us for a special clip.**

HARTCO FASTENERS AND CLINCHING TOOLS ARE COVERED BY ONE OR MORE OF THE FOLLOWING U.S. PATENTS, AS WELL AS OTHER FOREIGN PATENTS:

3,613,878      4,508,220  
 D-220,467      4,546,528  
 3,641,656      5,165,146  
 3,647,593

OTHER U.S. AND FOREIGN PATENTS PENDING.

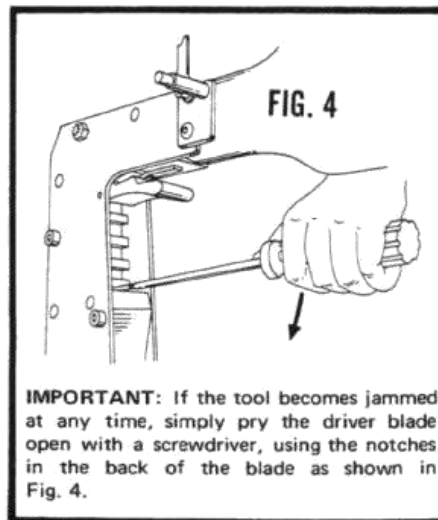

### Trouble Shooting

- If clips are loaded backward into the magazine with double ears forward, they will not be wrapped and jamming will occur. The first check of jammed tool should be to see that the clips are properly loaded in the magazine.
- Repeated jamming is usually caused by the operator placing the wires at the bottom of the anvil hook. This prevents the clip from passing around the wires and wrapping them. Wires must be located in the side plate notches for jam-free clinching.
- If tool does not actuate when trigger is depressed, the rear pilot valve may be stuck. To correct this, depress the trigger for an extended time and after the tool finally actuates, add a drop or two of oil at the air inlet.
- If the driver blade does not return freely, oil driver blade mechanism. If blade still does not return freely, disassemble one side plate to determine if binding occurs. If the problem continues, replace O-ring #43 in front of the housing.

For customer service and product support, contact:



... Innovating Legendary Products

**PackagingAndFastening.com**

USA Phone: 1-714-809-0194  
 www.packagingandfastening.com